

1. Details of Module and its structure

Module Detail	
Subject Name	Biology
Course Name	Biology 03 (Class XII, Semester - 1)
Module Name/Title	DNA and Search for genetic Material – Part 1
Module Id	lebo_10601
Pre-requisites	Knowledge about inheritance of characters
Objectives	After going through this lesson, the learners will be able to understand the following: <ol style="list-style-type: none">1. Deoxyribo nucleic acid2. Structure of DNA3. Packaging of DNA4. Transforming principle5. Hershey-Chase experiment6. Central Dogma
Keywords	Nucleoside, nucleotide, phosphodiester linkage, histone octamer, nucleosome, euchromatin, heterochromatin, transforming principle, bacteriophage

2. Development Team

Role	Name	Affiliation
National MOOC Coordinator (NMC)	Prof. Amarendra P. Behera	CIET, NCERT, New Delhi
Program Coordinator	Dr. Mohd. Mamur Ali	CIET, NCERT, New Delhi
Course Coordinator (CC) / PI	Dr. Chong V Shimray	DESM, NCERT, New Delhi
Course Co-Coordinator / Co-PI	Dr. Yash Paul Sharma	CIET, NCERT, New Delhi
Subject Matter Expert (SME)	Mr. Reetesh Kumar	RPVV, Civil lines, New Delhi
Review Team	Dr. Madhumita Banerjee	Ramjas College, University of Delhi.

Table of Contents :

1. Introduction
2. DNA and its Structure
3. Double helix model of DNA
4. Packaging of DNA helix
5. Transforming principle
6. Biochemical Characterization of Transforming Principle
7. Hershey-Chase experiment
8. Salient features of genetic material
9. Central dogma
10. Summary

1. Introduction

The work of Mendel was instrumental in working out the pattern of inheritance of traits from one generation to the other but the chemical nature of the genes or 'Merkmalen' as Mendel called them remained elusive for a long time. This is because there was a big question to be answered i.e., whether nucleic acids, proteins or both together, are the carriers of genetic information. This contention was based on the fact that the eukaryotic chromosomes have nucleic acids as well as the proteins. During the early 1950's many biologists were of the opinion that proteins have a greater diversity than the nucleic acids and so diversity of genes can be well attributed to them.

A series of experiments proved that that Deoxyribonucleic acid (DNA) is the genetic material in most organisms. The second type of nucleic acid- Ribonucleic acid (RNA) is the genetic material in some viruses.

In this section we will discuss what, exactly, is deoxyribonucleic acid, what are the monomers of this complex molecule, how are these monomers arranged. We will also deal with the experiments which proved the nature of genetic material.

2. Deoxyribonucleic acid (DNA) and its Structure

In 1869, a Swiss physician, Friedrich Miescher isolated a substance from the nucleus of white blood cells from the pus of wounded soldiers. The substance had a high phosphorous content and was acidic in nature. Since the substance was resistant to proteolysis (protein digestion) Miescher concluded that it was not a protein and realised that he had discovered a

new substance. He called it 'nuclein' as it was isolated from the nucleus. Nuclein was later identified as deoxyribonucleic acid.

Another polynucleotide called ribonucleic acid (RNA) was discovered later. Most organisms have DNA as the genetic material but some viruses, eg Tobacco Mosaic Virus (TMV), Human Immuno-deficiency virus (HIV) have RNA as their genetic material.

DNA is a fine, double stranded spirally coiled thread like polymer of deoxyribonucleotides found in the cells of the organisms. It is usually present in the nucleus of the cells of eukaryotic organisms. Some amount of DNA is also present in the organelles like mitochondria and chloroplasts. Prokaryotes eg, bacteria lack an organised nucleus and in these organisms DNA is present in the nucleoid region and in the plasmids present in the cytoplasm.

The length of DNA which stores the biological information of organisms can be estimated in various ways. It can be measured in terms of:

(i) Number of nucleotides if the DNA is single stranded for e.g., bacteriophage $\phi 174$ has 5386 nucleotides

(ii) Number of base pairs (bp) if the DNA is double stranded for e.g., Bacteriophage lambda has 48502 base pairs (bp), a haploid human cell has approximately 3.3×10^9 bp and the bacterium *Escherichia coli* has 4.6×10^6 bp (genomic i.e. nucleoid DNA). Plasmid DNA of bacteria is smaller as compared to the genomic DNA.

2.1 Structure of Polynucleotide Chain

Deoxyribonucleic acid (DNA) is a polymer composed of repetitive units (monomers) linked together to form a long chain. The repetitive units or monomers in a DNA strand are the nucleotides. Adjacent nucleotides are linked by phospho-diester bonds. Hence, DNA is polynucleotide.

A nucleotide has three components, a nitrogenous base, a pentose sugar and a phosphate group.

There are two types of Nitrogenous bases- purines and the pyrimidines. Adenine and Guanine are the two types of purines and both are found in the nucleic acids while the pyrimidines found in DNA are Thymine and Cytosine. Thymine found in DNA is replaced by Uracil (the third type of pyrimidine) in RNA. Thymine and Uracil are very similar molecules –Thymine is 5 methyl Uracil.

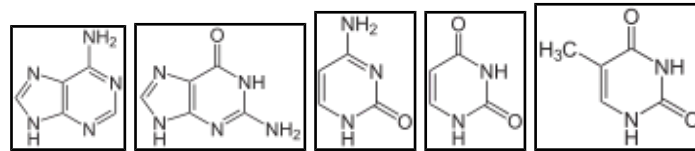

Adenine Guanine Cytosine Uracil Thymine

A nucleoside is formed when the nitrogenous base and the pentose sugar (deoxyribose sugar in case of DNA and ribose sugar in case of RNA) link together by N-glycosidic bond. The nucleosides found in DNA are deoxyadenosine, deoxyguanosine, deoxycytidine and deoxythymidine.

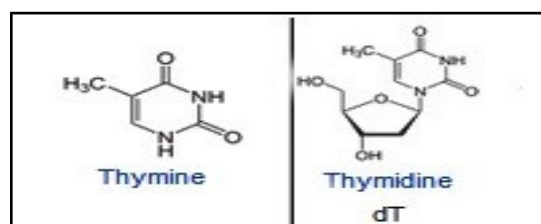
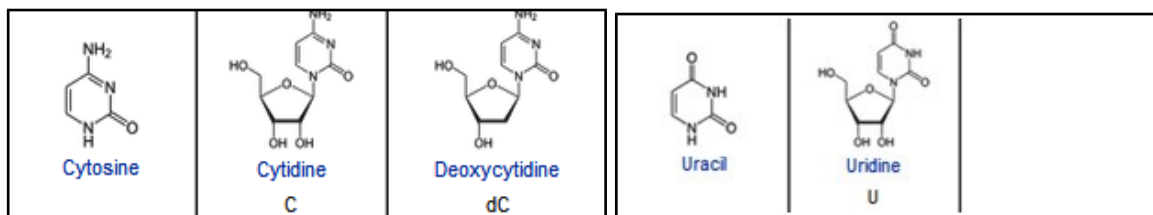
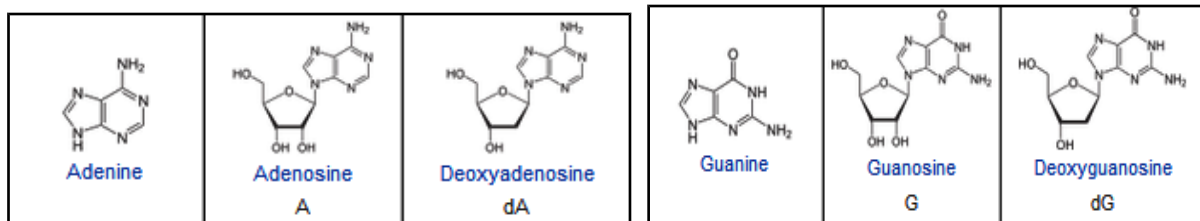

Nucleotide is formed when a phosphate group is linked to 5'-OH of a nucleoside through phosphoester bond. DNA has four types of nucleotides.

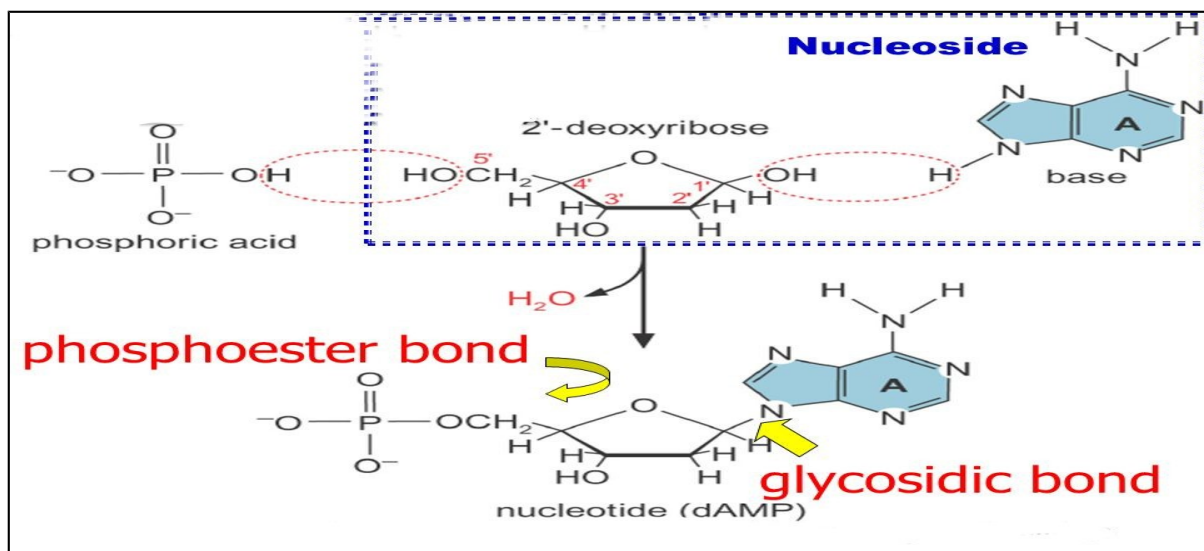

Two nucleotides are linked through 3'-5' phosphodiester linkage to form a dinucleotide.

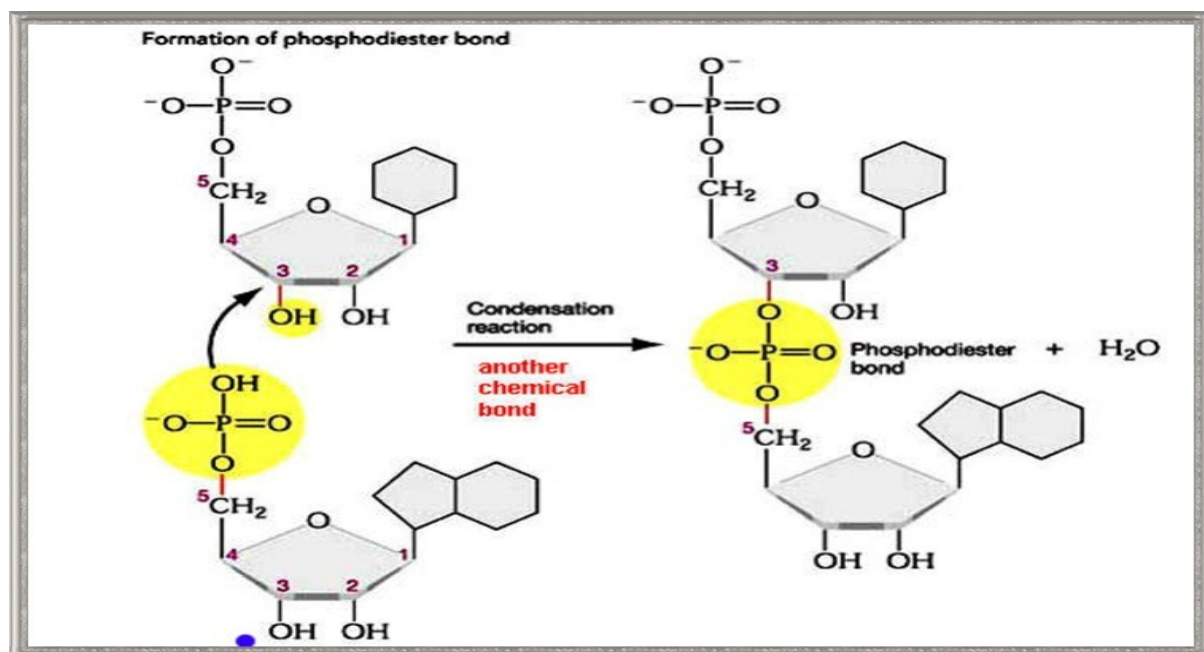

The polymer formed by the chain of nucleotides linked by the phosphodiester linkage has free phosphate moiety at 5'-end of ribose (or deoxyribose) sugar, called as 5'-end of polynucleotide chain. At the other end of the ribose (or deoxyribose) sugar of these nucleotides is present a free 3'-OH group which is called as 3' -end of the polynucleotide chain. The backbone of the polynucleotide chain is formed of the sugar and phosphates. The nitrogenous bases which are linked to the sugar moiety project from the backbone.

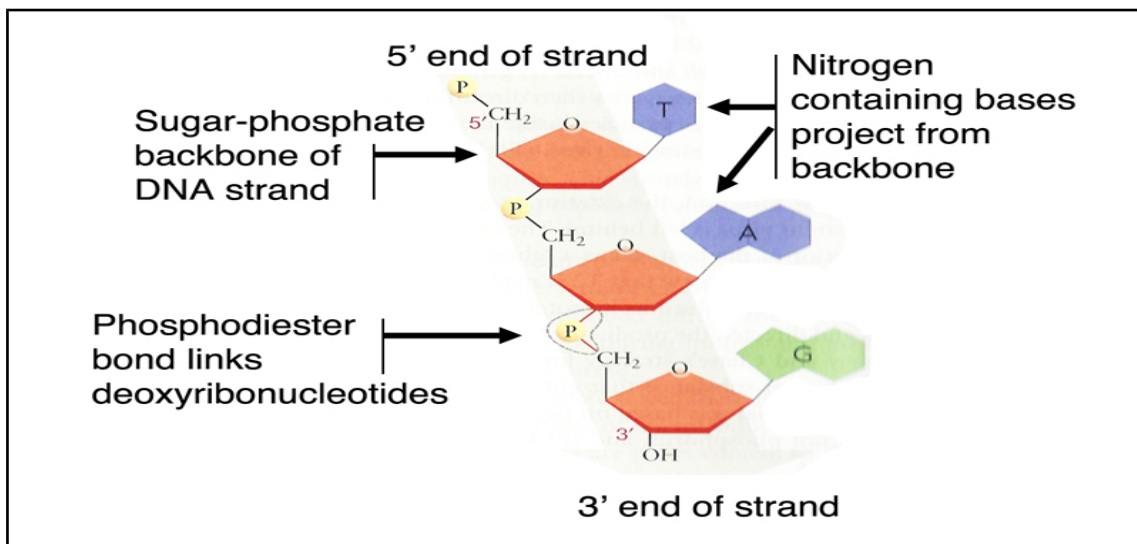

The polynucleotide appears like a chain of nucleotides with phosphate at 5' end and OH' at the 3' end.

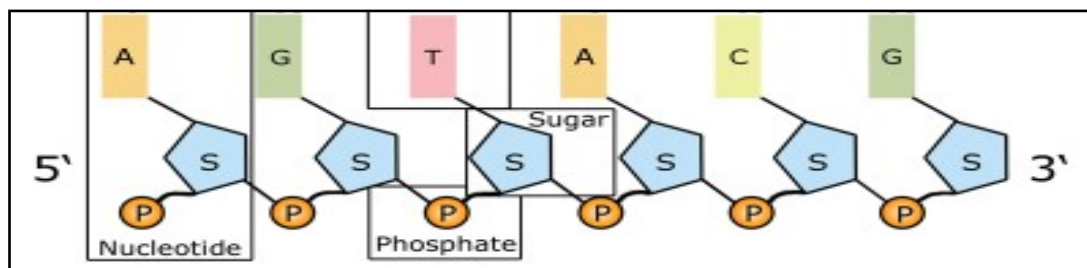

3. Double Helix model of DNA:

Fredrick Miescher's discovery of nuclein is a big landmark in the history of genetic research. In 1881 Albrecht Kossel, a German biochemist identified nuclein as a nucleic acid, gave its chemical name- deoxyribonucleic acid (DNA) and also isolated nucleotides present in DNA and RNA i.e., adenine, guanine, cytosine thymine and uracil.

Later researches done by scientists like Phoebus Levene and Erwin Chargaff revealed many details about DNA.

Levene discovered the following:

- i. The order in which the three components of a single nucleotide are placed, i.e., phosphate-sugar-base;
- ii. The carbohydrate component of RNA (ribose);
- iii. Carbohydrate component of DNA (deoxyribose);
- iv. The way RNA and DNA molecules are put together.

Rosalind Franklin and Maurice Wilkins obtained high-resolution X-ray images of DNA fibers that suggested a helical, corkscrew-like shape.

Linus Pauling's discovery of the single-stranded alpha helix found in many proteins prompted biologists to think of helical forms for DNA.

In 1953, the double helix model of DNA was elucidated by James Watson and Francis Crick for which they got Nobel Prize along with Maurice Wilkins. Franklin missed the Nobel Prize as the prize is not awarded posthumously. Their model was based upon the earlier insights into the structure of DNA along with the works of Erwin Chargaff, Rosalind Franklin and Maurice Wilkins.

Erwin Chargaff concluded that the total amount of purines (A + G) and the total amount of pyrimidines (C + T) are usually nearly equal and equal to one. This conclusion is known as Chargaff rule. The amount of purines is equal to the amount of pyrimidines. However A+T may not be equal to G+C.

Chargaff's rule which held that $A = T$ and $C = G$, formed the basis on which the Watson and Crick model predicted the base pairing between the complementary nitrogenous bases. This unique base pairing property (A always base pairs with T and G with C) helps in predicting the sequence of bases in the other strand if the sequence of bases in one strand is known.

(ii) The X-ray crystallography work done by Franklin and Wilkins demonstrated that the two sugar-phosphate backbones lay on the outside of the molecule. This confirmed Watson and Crick model of DNA that the sugar-phosphate backbones formed a double helix that they were anti-parallel i.e. in a DNA double helix the 5' end of one DNA strand pairs with the 3' end of the complementary strand.

The most common conformation in most living cells one proposed by Watson and Crick is known as B-DNA.

The Double-helix structure of DNA more commonly found as B- DNA in the organisms has the following salient features:

(a) It consists of two polynucleotide chains where the backbone is constituted by sugar-phosphate. The nitrogenous bases project towards inside from the sugar-phosphate backbone. The two chains have anti-parallel polarity because the 5' end of one strand is paired with the 3' end of its complementary strand.

The phosphate groups link the successive nucleotides to each other by binding the 3' end of sugar one nucleotide to the 5' end of the sugar of the next nucleotide. Due to this arrangement, if one chain has the polarity 5'-3', the other has a polarity of 3' – 5'.

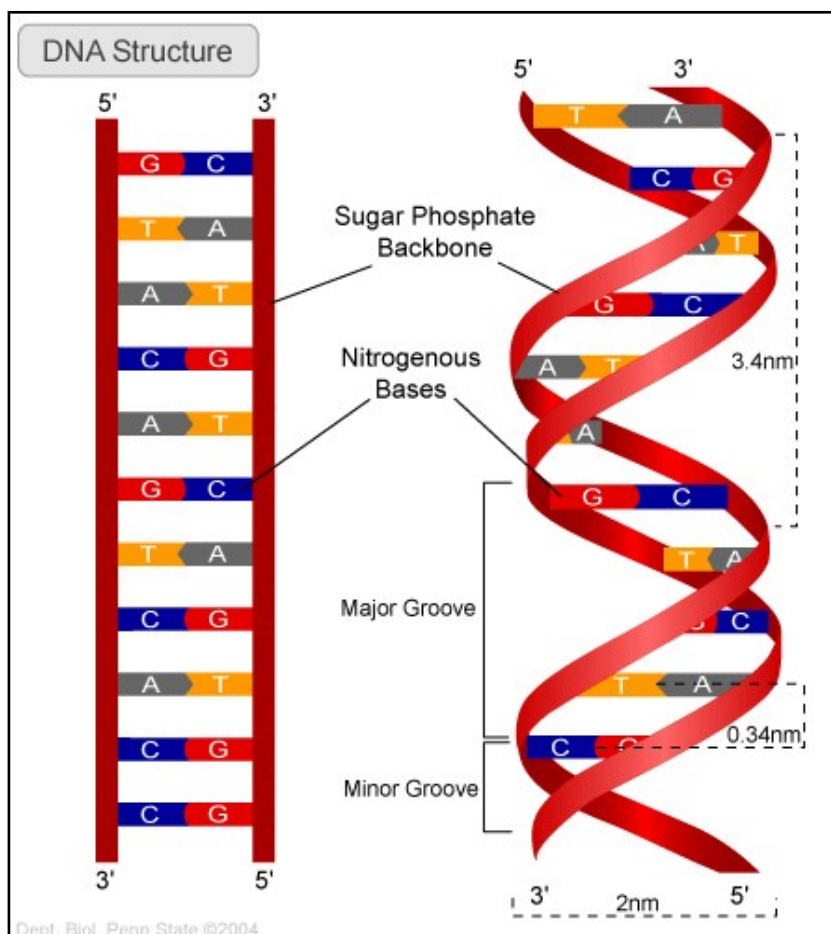
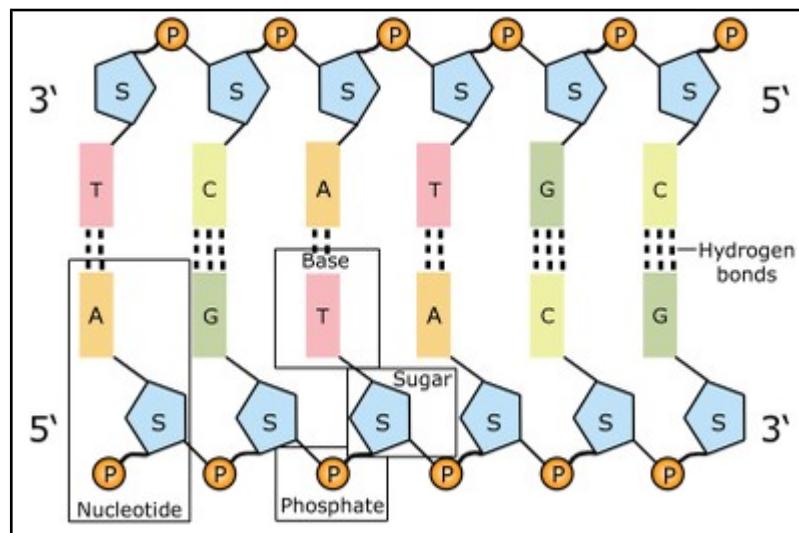

The bases in two strands are paired through hydrogen bond (H-bonds) forming base pairs (bp). Adenine is paired with Thymine of opposite strand by two hydrogen bonds and vice-versa.

In the same way, Guanine is bonded with Cytosine of opposite strand with three H-bonds and vice versa.

The two chains are coiled in a right-handed fashion i.e., if you hold your right hand out, with your thumb pointed up then your thumb would represent the axis of the helix. Now, curl your

fingers around your thumb, your fingers would represent the sugar-phosphate backbone wrapped around the helix in right handed fashion. DNA and the other forms of DNA are right handed helix. Only one type of DNA called the Z-DNA, has a left-handed helix.

The pitch of the helix (one complete turn of the helix), is 3.4 nm and consists of roughly 10 base pairs (bp) in one complete turn.

The distance between one base pair (bp) in a helix is approximately equal to 0.34 nm.

The diameter of the double helix is 2 nm . It remains constant because a purine always base pairs with a pyrimidine.

The plane of one base pair stacks over the other in the double helix. This type of stacking of bases one over the other along with the Hydrogen bonds present between them confers a high degree of stability to the helical structure.

There are two other conformations of DNA which occur in special cases. These are:

A shorter and wider form found in dehydrated samples of DNA and rarely under normal physiological circumstances is called as the A-DNA.

A left-handed conformation which is a transient form of DNA formed in response to certain types of biological activity like protection against viral disease (Rich & Zhang, 2003), is called as the Z-DNA.

Packaging of DNA Helix:

The haploid human genome (present in sperms and ova) contains approximately 3.3×10^9 base pairs of DNA which is packaged into 23 chromosomes. The diploid content of human genome is 6.6×10^9 base pairs. The distance between two consecutive base pairs is 0.34 nm (0.34×10^{-9} m), so the length of DNA double helix in a typical mammalian cell is around $6.6 \times 10^9 \text{ bp} \times 0.34 \times 10^{-9} \text{ m/bp} = 2.2 \text{ metres}$. About 50 trillion cells are present in human body which sums up to around 100 trillion metres of DNA in a human. It sounds very astonishing and surprising that a single human being has enough length of DNA to go to Sun which is 150 billion metres away from Earth and come back 300 times. It can encircle the Earth's equator 2.5 million times. This huge amount of DNA requires very complicated and intricate packaging machinery.

No well defined nucleus is present in the prokaryotes such as *E. coli*, but its DNA is not scattered throughout the cell. The negatively charged DNA of prokaryotes is held with some positively charged proteins in a region termed as '**nucleoid**'.

A much more complex organization is found in the eukaryotic cells as mentioned below. DNA is negatively charged due to phosphate groups present in its phosphate-sugar backbone. Histones are positively charged proteins due to presence of excess of the basic amino acids

called lysine and arginine. These amino acids have positive charges in their side chains. Histones are termed as H1, H2A, H2B, H3, and H4. Two each of the histones H2A, H2B, H3, and H4 form a protein octamer around which DNA gets tightly wrapped in order to get accommodated in the nucleus of a eukaryotic cell.

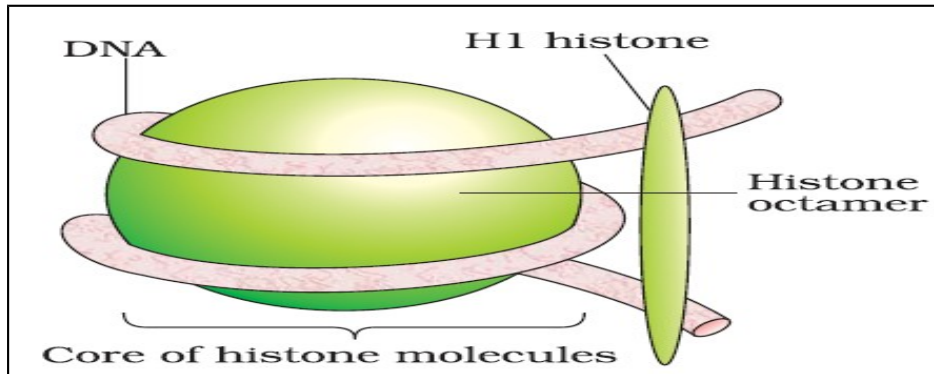

The histones provide the energy in the form of electrostatic interactions to fold DNA

resulting in the formation of a DNA- protein complexes. The repeating structural and functional units of chromatin are 'nucleosomes' which are formed by wrapping of the negatively charged DNA around the positively charged histone octamer.

A nucleosome consists of around 1.7 turns of DNA, or about 146 base pairs and one H1 histone wraps another 20 base pairs. This result in two full turns around the octamer, and forms a structure called as chromatosome. Histone H1 acts as lock, fastening the DNA at the points in which it enters and leaves the nucleosome.

Thousands of nucleosomes are present in a chromosome. Nucleosomes are linked by a stretch of DNA called linker DNA. The length of the linker DNA is variable between species and also tissues of the same organism. DNA is present between two nucleosomes Thus, the nucleosomes in chromatin are seen as '**beads-on-string**' structure when viewed under electron microscope (EM).

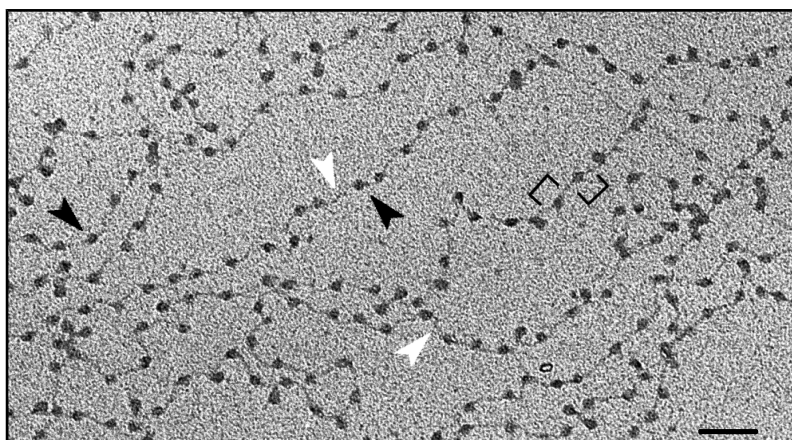

The length of chromatin fiber gets shortened by about seven-fold due to the packaging of DNA into nucleosomes. Further coiling of the fiber consisting of the nucleosomes converts it

into a shorter, thicker fiber which has a diameter of approximately 30 nanometers and is called as the "30-nanometer fiber" or solenoid structure. These are further coiled and condensed at metaphase stage of cell division with the help of additional set of proteins which are collectively called as Non-histone Chromosomal (NHC) proteins to form the metaphase chromosomes.

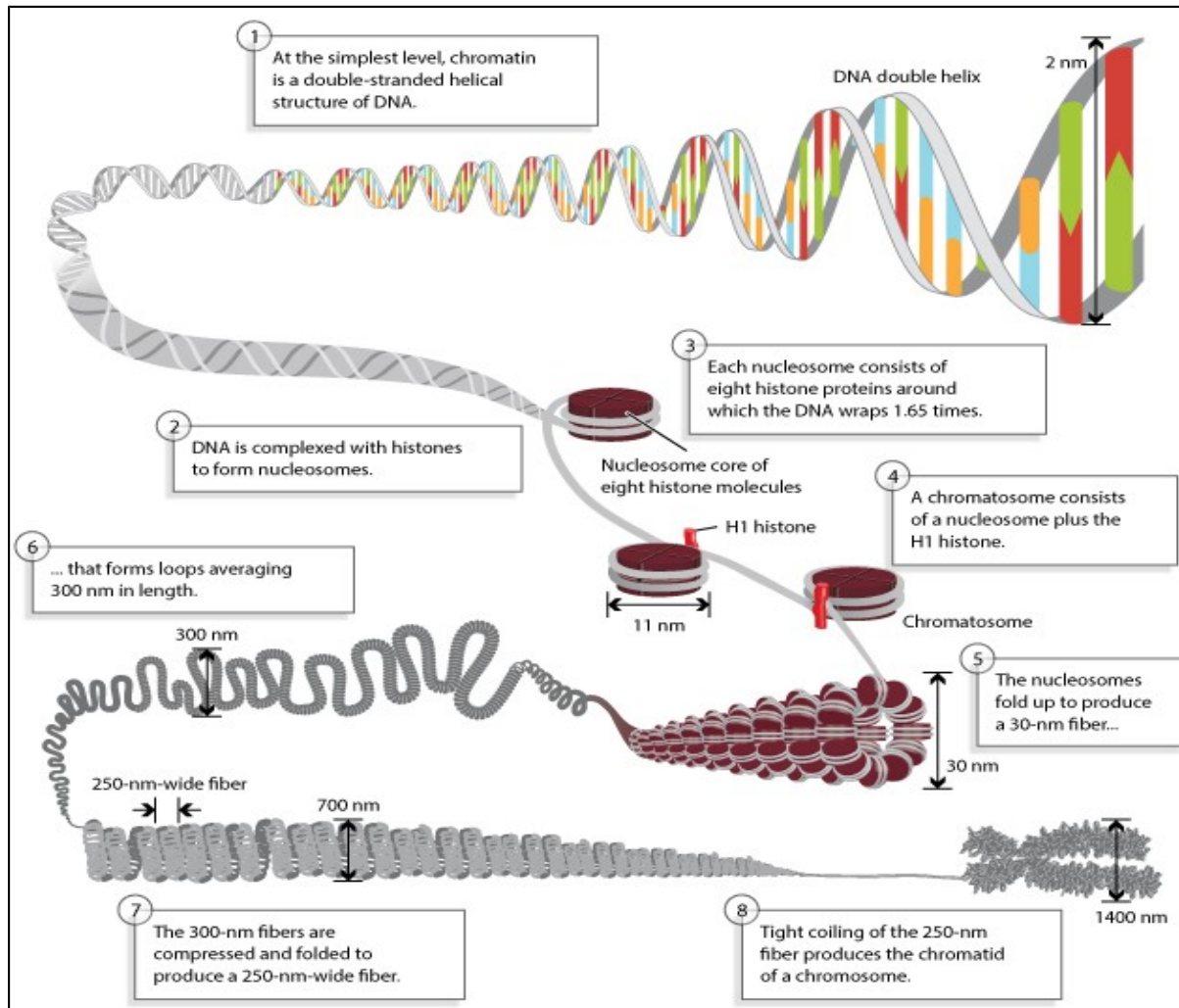

The chromatin of a typical nucleus has two regions: Heterochromatin and Euchromatin. The two types of chromatin are functionally and structurally distinct regions of the genome.

Heterochromatin: more tightly and densely packed region of chromatin which cannot undergo recombination during meiosis, is transcriptionally inactive and stains dark.

Euchromatin: loosely packed and less dense region of chromatin which can undergo recombination during meiosis, is transcriptionally active and stains light.

- Histone Acetylation removes the positive charges on the histones decreasing its level of attraction to DNA (which is negatively charged) causing uncoiling and results in more active transcription in such regions called as euchromatin.

Histone or DNA Methylation makes histone or the DNA more hydrophobic which causes it to clump up in the hydrophilic environment and results in transcriptionally inactive regions called heterochromatin.

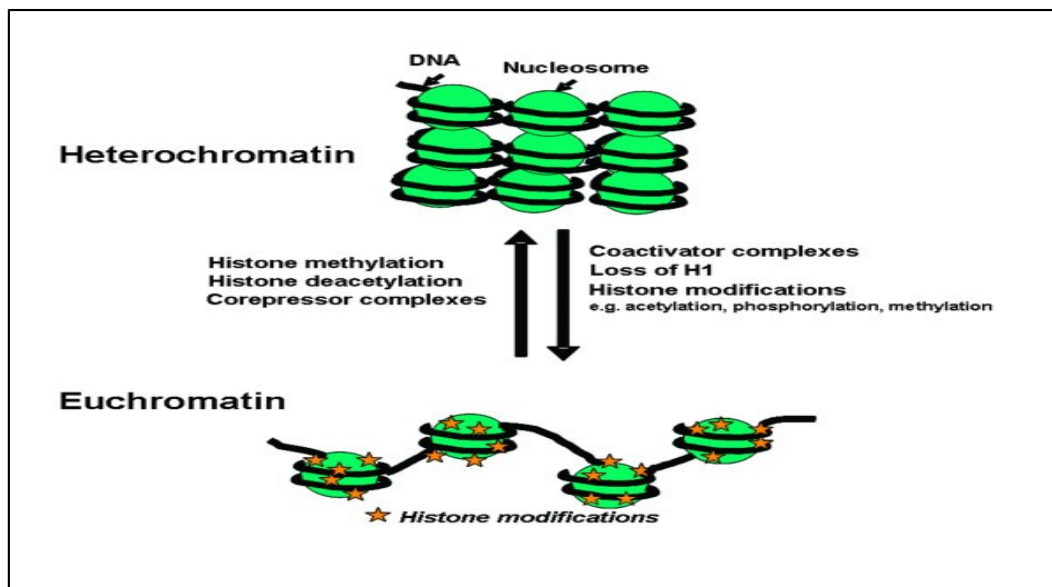

Chromosome Parts:

- **Heterochromatin:**
 - More condensed
 - Silenced genes (methylated)
 - Gene poor (high AT content)
 - Stains darker
- **Euchromatin:**
 - Less condensed
 - Gene expressing
 - Gene rich (higher GC content)
 - Stains lighter

Transforming Principle Experiment by Frederick Griffith:

In 1928 Frederick Griffith carried out a series of experiments with *Streptococcus pneumoniae*, a bacterium responsible for causing the disease pneumonia. The bacterium is also called as *Diplococcus pneumoniae* or *Pneumococcus* bacteria. Griffith witnessed a miraculous transformation of the bacteria during the course of his experiment wherein the bacteria changed in physical form when it received DNA through a process called transformation.

The pneumococcus bacterium occurs naturally in two forms- the virulent (S-strain or smooth strain) form which has a smooth polysaccharide capsule and form smooth shiny colonies on a culture medium. The capsule makes the strain resistant to degradation by the WBC of mice and therefore the smooth strain causes infection. The other form called the non-virulent (R-strain or the rough strain) lacks the polysaccharide capsule and forms a rough colony on culture medium. R-strains are non virulent as the WBC of the mice destroys the R-strain bacteria.

Mice injected with S-strain of the pneumococcus bacteria die within a few days due to pneumonic infection. The mice injected with the R-strain bacteria continue to live as the immune system of the mice destroys the R strain bacteria. The mice injected with the heat-killed S-strain bacteria also survive.

The R and S strains have been further classified as Type I,II, III, etc based on the molecular composition of polysaccharides.

When Griffith injected the mice with a mixture of heat-killed SIII-strain and a live but non-virulent RII-strain .He was surprised that the combination produced lethal results. He was astonished when he discovered living forms of the SIII-strain bacteria in the infected mice.

Griffith concluded that the R-strain (non-virulent) bacteria had somehow been transformed by the heat-killed S-strain bacteria. This could not be due to mutation as in that case RIII strains would be recovered from the bacteria formed by mutation of the SIII strain. He concluded that transformation would have occurred due to the transfer of genetic material from the heat-killed S-Strain to the R- strain. He hypothesised that some "transforming principle", transferred from the heat-killed S-strain, had enabled the R-strain to synthesize a smooth polysaccharide coat and convert into virulent S-strain. He called the phenomenon transformation of bacteria. However, he was not able to define the biochemical nature of transforming material through his experiments.

Biochemical Characterization of Transforming Principle

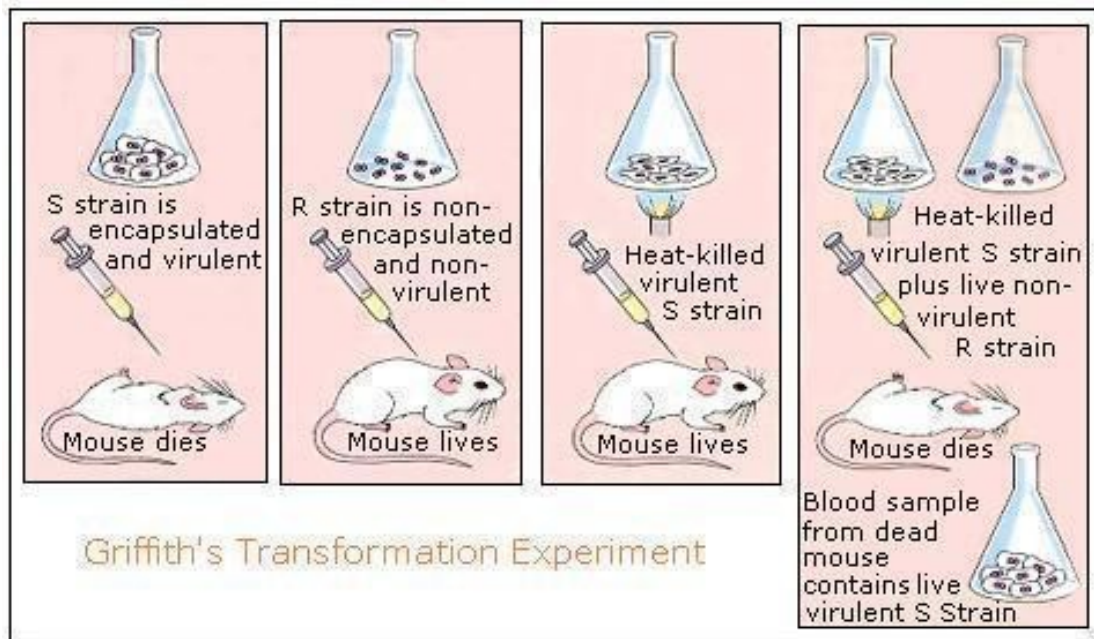

In 1944, the team of Avery, MacLeod and McCarty analyzed the Griffith's experiment and attempted to find the biochemical nature of the 'transforming principle'. They extracted nucleoid purified DNA, proteins, RNA and other materials from the heat-killed S-strain bacteria (*Streptococcus pneumoniae*) and mixed R-strain bacteria with these different materials. They found that only those R-strain bacteria which were mixed with only DNA from the heat killed S-strain were transformed into S-strain bacteria. A test tube assay was used by them instead of mice for their experiments.

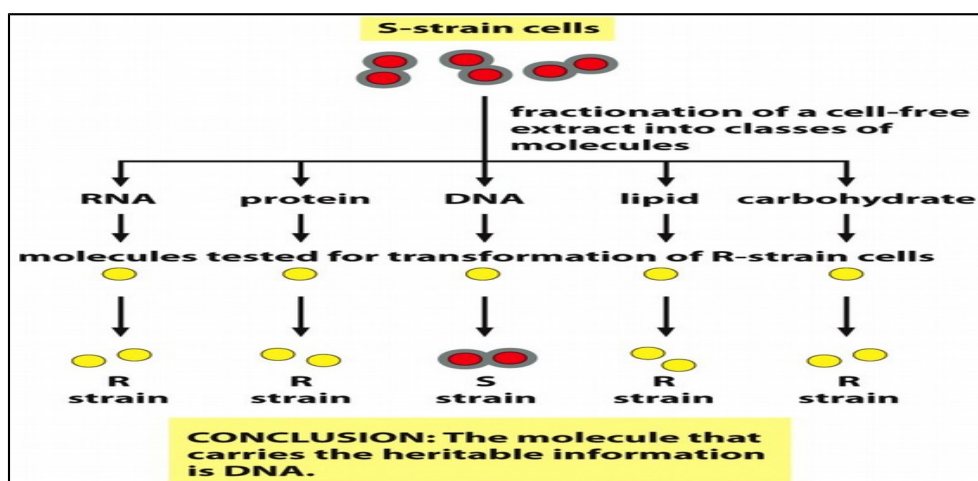

In another set of experiments, the heat killed SIII strain was treated in three different ways:

- Protease (enzyme which breaks down protein),
- RNase (enzyme which breaks down ribonucleic acid), and
- DNase (enzyme that breaks down DNA).

The SIII-strain which had been individually treated with a different enzyme was taken in three separate test tubes and exposed to live RII strain bacteria. The mixture was cultured on an agar medium

The results were as follow

1. Heat killed SIII + living RII + protease -----III S colonies were formed on culture medium
2. Heat killed SIII+living RII+ RNase -----IIS colonies formed on culture medium
3. Heat killed SIII+living RII+DNase----- No conies on culture medium

Conclusion : transformation of RII to SIII occurs in test tubes 1and2. No transformation occurs in test tube 3, as DNA has been degraded by the enzyme DNase .

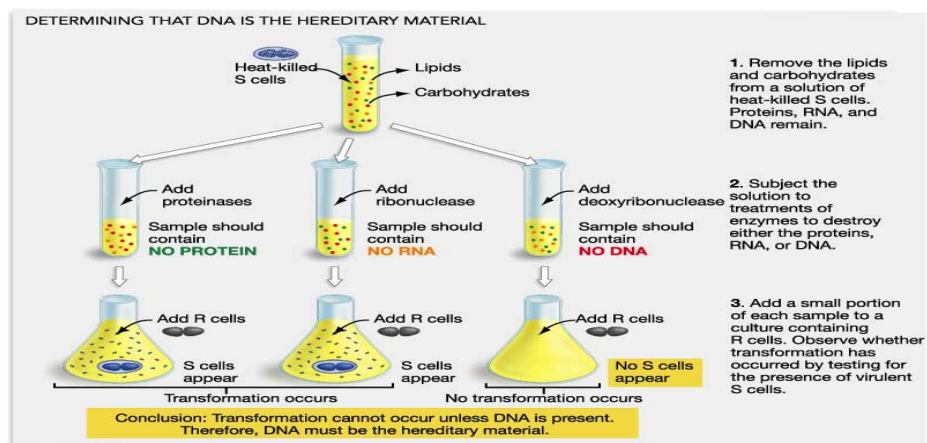

Therefore, they concluded that DNA is the ‘transforming principle’ or “transforming factor” and not the proteins, RNA or any other material.

Hershey Chase Experiment

In 1952, Alfred Hershey and Martha Chaseworked on the T2-bacteriophage and were able to conclusively prove that DNA is the genetic material present in the organisms. Bacteriophages are the viruses which attach to bacterial cell,I nsert their genetic material into the bacterium and infect it. The bacterium treats the viral genetic material as its own and manufactures more viral particles.

They first grew the some viruses in radioactive Sulphur (S-35) containing medium and other viruses in radioactive Phosphorus (P-32) containing medium. Radioactive sulphur (S-35) gets exclusively incorporated into the protein coat of the virus whereas the radioactive phosphorus (P-32) gets exclusively incorporated into the DNA of the virus.

Their experiment is also known as Hershey-Chase blender experiment. The experiment was carried out in three steps:

- a) **Infection:** Bacteria were infected with the two kinds of viruses :
- Viruses with their protein coat radius labelled with S-35.
 - Viruses with their DNA radius labelled with S-32.

Blending: This was done to separate the viral protein coat from the bacterial cell. The viral protein gets dislodged from the bacterial cell by this process.

Centrifugation: This was done to separate out the viral coat in supernatant and bacterial cells formed the pellet at bottom.

Result:

On analysis they found that most of the S-35 radioactivity was in the supernatant with the viral coat while most of the P-32 radioactivity was detected in the pellet with the bacteria.

They concluded that proteins did not enter bacteria but the DNA had entered the bacteria, so DNA is the genetic material.

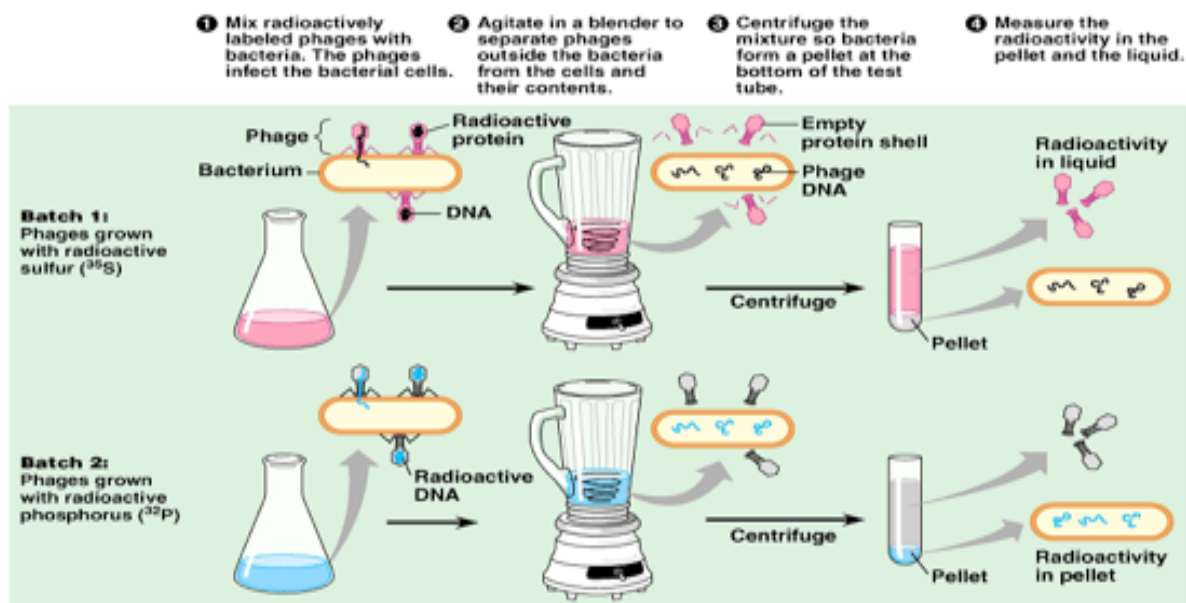

(b) The experiment showed that T2 proteins remain outside the host cell during infection, while T2 DNA enters the cell.
Copyright © Pearson Education, Inc., publishing as Benjamin Cummings.

Characteristics of Genetic material:

The characteristics of the genetic material (i.e., the material that determines the inherited characteristics of a functional/living organism) are:

- (i) It should be able to generate its replica (Replication).
- (ii) It should chemically and structurally be stable.

-
- (iii) It should provide the scope for slow changes (mutation) that are required for evolution.
 - (iv) It should be able to express itself in the form of 'Mendelian Characters'.

The Central dogma

The central dogma of molecular biology was proposed by Francis Crick on basis of complementarity of base pairs. It describes the two-step process called as transcription (formation of RNA from DNA) and translation (formation of proteins from RNA), by which the information in genes flows into the mRNA (transcription) and then into protein (translation). However in RNA viruses, where the genome is made of RNA, DNA is transcribed from RNA by a process called reverse transcription. Reverse transcription requires the presence of an enzyme called reverse transcriptase discovered by Temin and Baltimore.

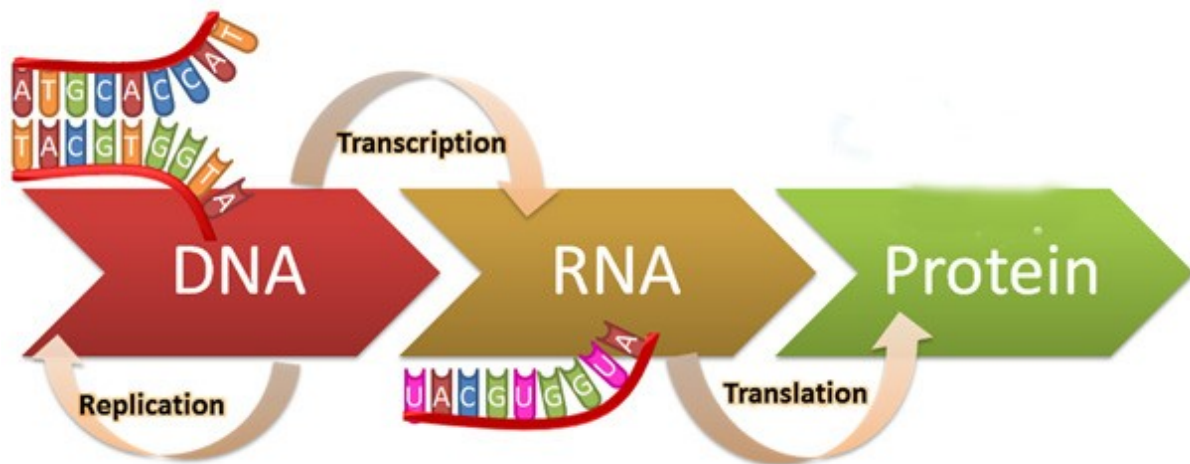

Summary

DNA is a double helix with a sugar phosphate backbone and nitrogenous bases projecting towards inside. The nitrogenous bases are linked together by hydrogen bonds. The discovery of structure of DNA by Watson and Crick was a turning point in the history of molecular biology. The DNA is a long polymer of nucleotides packed within the nucleus of cells with the help of special positively charged basic proteins called as the histones. The search for genetic material led Griffith to find a transforming principle which was responsible for the transformation of bacteria. The biochemical nature of the transforming principle was revealed by the experiments done by three scientists namely Avery, MacLeod and McCarty. However, the conclusive proof that DNA is the genetic material came from the Blender experiment carried out by Alfred Hershey and Martha Chase which put to rest a lot of controversy which was there regarding the nature of genetic material present in the living organisms. DNA is considered the most ideal genetic material due to the characteristic features it has. The central

dogma was proposed by Francis Crick to explain the flow of genetic information within a biological system which leads to formation of proteins and helps to express a particular character in the living organism.